

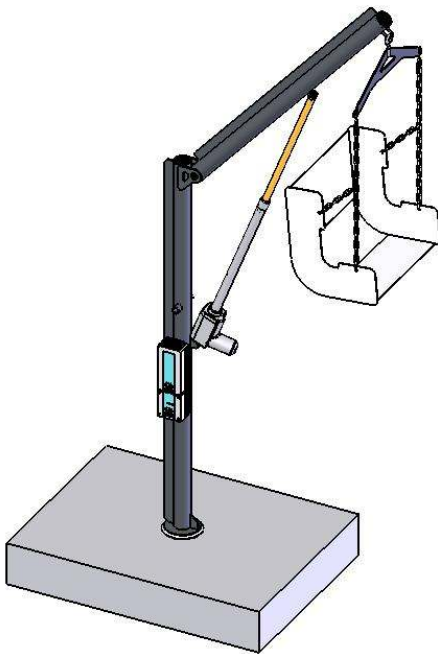

# Aqua Creek Products

The Total Solution for Pool and Spa Access



## **SUPER POWER-EZ™ POOL LIFT**

### **Installation, Assembly and Operation Instructions**

**400 lb. (181 kg) MAXIMUM LIFTING CAPACITY**

#### **- WARNING -**

##### **IMPORTANT SAFETY INSTRUCTIONS**

- 1. READ AND FOLLOW ALL INSTRUCTIONS. LIFT SAFETY CAN ONLY BE ENSURED IF THE LIFT IS INSTALLED AND OPERATED PROPERLY – ACCORDING TO THESE INSTRUCTIONS.**
- 2. TO REDUCE THE RISK OF INJURY, DO NOT PERMIT CHILDREN TO USE THIS PRODUCT UNLESS THEY ARE CLOSELY SUPERVISED AT ALL TIMES.**
- 3. DO NOT PERMIT CHILDREN TO PLAY ON OR AROUND THIS PRODUCT.**
- 4. NEVER APPLY DIRECT WATER PRESSURE TO THE ELECTRONIC COMPONENTS.**
- 5. SAVE A COPY OF THESE INSTRUCTIONS IN A SAFE AND EASILY ACCESSIBLE PLACE.**

**AQUA CREEK PRODUCTS**  
**9889 GARRYMORE LANE**  
**MISSOULA, MT 59808**

*Toll Free: 1-888-687-3552 • Fax: 1-406-549-2602 • Web: [www.aquacreek.com](http://www.aquacreek.com)*

# TABLE OF CONTENTS

<b>SUPER POWER-EZ PARTS LIST</b>	<b>3</b>
<b>RETRO-FIT ANCHOR INSTALLATION</b>	<b>4-5</b>
<b>NEW-CONSTRUCTION ANCHOR INSTALLATION</b>	<b>6</b>
<b>LIFT INSTALLATION &amp; ASSEMBLY</b>	<b>7-8</b>
<b>OPERATING INSTRUCTIONS</b>	<b>9-10</b>
<b>24V BATTERY SYSTEM INSTRUCTIONS</b>	<b>11-12</b>
<b>TROUBLESHOOTING GUIDE</b>	<b>13-15</b>
<b>SAFETY AND MAINTENANCE INSTRUCTIONS</b>	<b>16-17</b>
<b>SUPER POWER-EZ EXP PARTS LIST</b>	<b>18</b>
<b>WARRANTY INFORMATION</b>	<b>19</b>

## - READ CAREFULLY -

*Check entire box and inside all packaging materials for parts. Before beginning assembly, read the instructions and identify parts using the figures and parts lists in this document. It is critical that all parts be carefully inspected by the installer prior to installation to ensure that no damage occurred in transit and that a damaged part is not used. If any damage occurred in transit or you are missing parts, notify Aqua Creek Products Immediately! Failure to notify Aqua Creek of damaged or missing parts within 3 days of receipt of shipment may affect your ability to receive replacement parts. Proper installation cannot be overstressed – improper installations will void the warranty and may affect the safety of the user.*

# THE SUPER POWER-EZ LIFT

The SUPER Power-EZ Lift™ arrives partially assembled in multiple boxes. Begin by removing all parts from the boxes and locating the parts for your lift in the parts lists below. Refer to the parts breakdown drawings in the back of this manual for assistance.

## PARTS LIST: SUPER POWER-EZ LIFT

<b>BOX "A" CONTENTS (ANCHOR INCLUDED)</b>		
ITEM #	QTY.	DESCRIPTION
1	1	SUPER POWER-EZ MAST

<b>BOX "B" CONTENTS (ANCHOR INCLUDED)</b>		
ITEM #	QTY	DESCRIPTION
1	1	SUPER POWER-EZ BOOM ARM

<b>BOX "C" CONTENTS (ANCHOR INCLUDED)</b>		
ITEM #	QTY	DESCRIPTION
1	1	TURNING BAR
2	1	TURNING RING
3	1	ANCHOR
4	1	24V CONTROL BOX
5	1	24V BATTERY CHARGER
6	1	HAND CONTROLLER
7	1	24V BATTERY
8	1	EZ SLING
9	1	EZ CHAIN SET
10	1	EZ HANGER
11	4	EZ SLING BARS
12	1	LA-34 ACTUATOR

<b>HARDWARE BAG (BOX C)</b>		
ITEM #	QTY	DESCRIPTION
1	1	1/2" X 4" HEX BOLT
2	1	1/2" NYLOCK NUT
3	2	1/2" FLAT WASHER
4	2	3/8" X 1-3/4" S.S. HEX BOLT
5	2	3/8" S.S. NYLOCK NUT
6	4	3/8" S.S. FLAT WASHER
7	1	#10-24 – 3/8" S.S. BUTTON HEAD

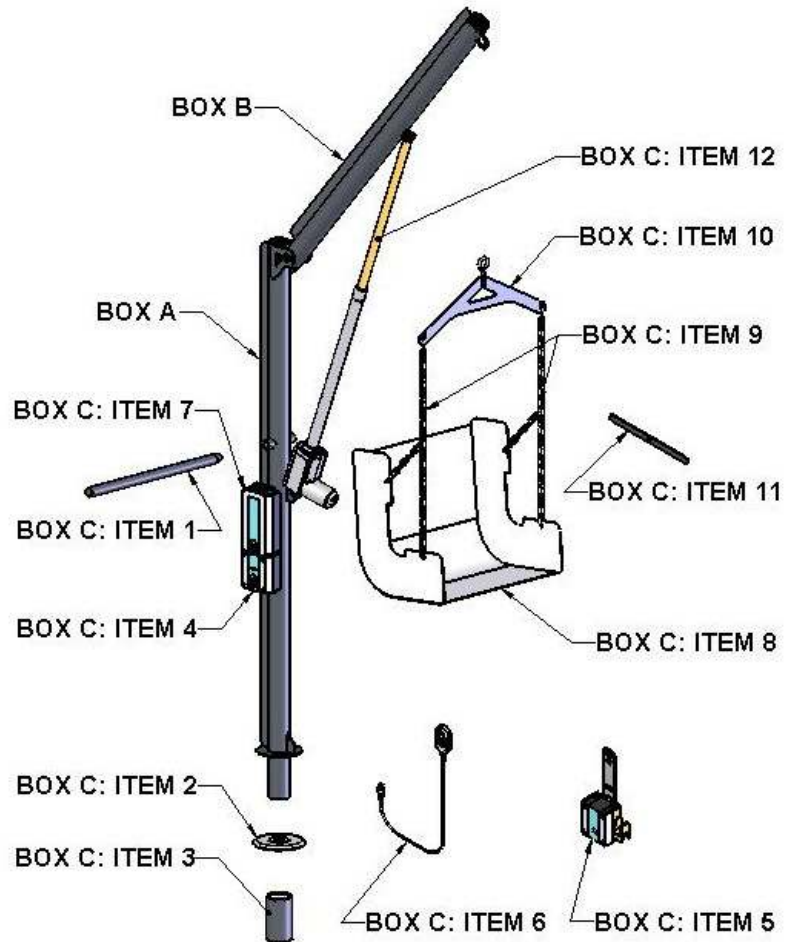

## SUPER POWER-EZ ANCHOR INSTALLATION INSTRUCTIONS

**NOTE:** The SUPER Power-EZ Pool Lift™ comes standard with a 6" deep anchor socket that is installed into a concrete deck. Anchor options include a surface mount anchor and a wood deck anchor system both purchased separately. The SUPER Power-EZ Pool Lift™ standard 6" anchor system can be installed in an existing pool deck (Retro-fit installation) or when pouring a new concrete pool deck (New construction installation). If the anchor has already been installed you can move on to the assembly section of this manual that is appropriate to the lift you purchased.

### RETRO-FIT ANCHOR INSTRUCTIONS:

**NOTE:** The concrete deck around the anchor system should be a minimum of 8" thick and should be reinforced with #4 reinforcing bars spaced on 10" centers in each direction. The total concrete pad area should be at least 60" wide (measured away from the pool edge) and 60" long (parallel with the pool edge).

### **REQUIRED TOOLS (Core Drilling Method)**

Tape Measure	Core Drill
4" [10 cm] Core Drill Bit	Electrical tape
*2-part Anchor Adhesive	Small Carpenters Level
Felt Tip Marking Pen	Vacuum or compressed air source

\*Use Simpson ET22 Strong Tie or Hilti HIT HY-150 Anchor Adhesive

### **STEP 1:**

Determine the best location for the lift. Make sure the location includes enough clear deck space to easily transfer into the lift seat. Keep in mind this lift will require assistance from another person to operate and you should locate it in an area that can accommodate another person. The lift should also be located so as to provide at least 6' [1.8 m] of unobstructed deck to each side of the lift to accommodate easy maneuvering of the lift over the water and back. The lift should also be located according to the chart on the right. The SUPER Power-EZ lift will function optimally only if the lift is placed at the proper setback distance. Placing it too close will cause the lifting handle or the hydraulic ram to come into contact with the wall. Placing the lift too far away will cause the seat to hit the wall.

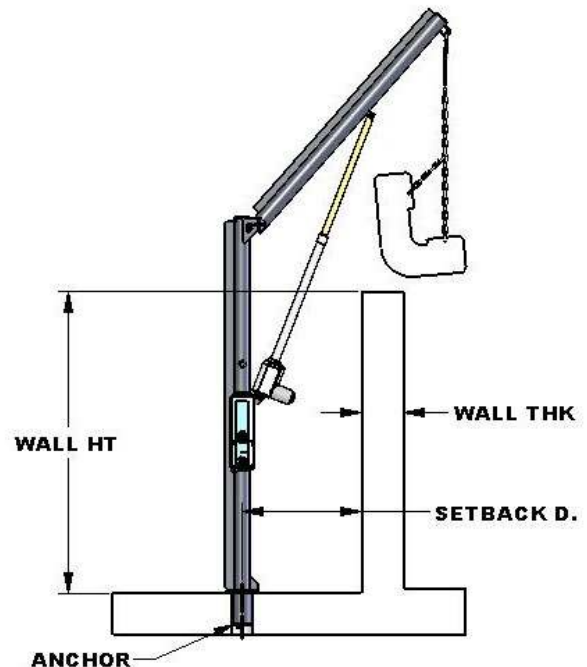

SUPER POWER-EZ SETBACK & WALL THK		
WALL HT	MAX THK	SETBACK D.
58"	8"	24"
56"	9"	24"
54"	10"	23 1/2"
52"	11"	23"
50"	12"	22 1/2"
48"	14"	22"

**STEP 2:**

Locate the concrete anchor socket that came with your lift. Be careful to not lose the protective cap on the anchor. This will be used to keep dirt and debris out of the socket when the lift is not installed in the anchor.

**STEP 3:**

The setback to the center of the anchor is determined from the chart on page 5. The anchor location must also be at least 6" [15 cm] from any control joint or edge of concrete slab. Measure the location out using your tape measure and marking pen. (Reference the drawing on the next page for details).

**STEP 4:**

Core drill at least a 4" [10 cm] diameter hole at the desired location for the lift anchor socket. The hole will need to be at least 7" [18 cm] deep to allow for the grounding lug which protrudes from the bottom of the anchor. Depending on the thickness of your concrete slab, you may drill completely through the slab and into the underlying dirt.



**TIP:** Use the electrical tape to make a mark on your drill bit at 7" [18 cm] as a depth mark to tell you when to stop drilling.

**STEP 5:**

Clean out the hole and make sure your hole is deep enough to allow the anchor to be flush with the finished deck surface. Use a stiff wire brush and scrub the sides to ensure they are free from dirt or loose particles. Then use an air nozzle to blow out as much loose material as possible. The hole should be as clean and dry as possible.

**STEP 6:**

Ground the anchor according to your local code requirements. (This may require additional drilling and/or other tools).

**STEP 7:**

Install the anchor epoxy in its dispenser and make sure the epoxy is fully mixed as it comes out the nozzle before filling the hole (the epoxy will be a uniform color when fully mixed). Starting at the bottom of the hole fill it 1/3 to 1/2 full.

**STEP 8:**

Press the anchor into the hole with a twisting motion. Press it down until it is level with the deck surface. Check the anchor for level and plumb. If the epoxy doesn't fill the hole to the top add more around the sides until the epoxy is also level with the surface. Make sure there are no voids or gaps in the epoxy. Let cement or epoxy cure for 24 hours (or minimum manufacturer's recommendations) before using lift.

## **SUPER POWER-EZ NEW CONSTRUCTION ANCHOR INSTALLATION**

**NOTE:** The concrete deck around the anchor system should be a minimum of 8" thick and should be reinforced with #4 reinforcing bars spaced on 10" centers in each direction. The total concrete pad area should be at least 60" wide (measured away from the pool edge) and 60" long (parallel with the pool edge).

### **REQUIRED TOOLS**

Tape Measure  
String Level

Small Carpenters Level  
String Line

#### **STEP 1:**

Determine the best location for the lift. Make sure the location includes enough clear deck space to easily transfer into the lift seat. Keep in mind this lift will require assistance from another person to operate and you should locate it in an area that can accommodate another person. The lift should also be located so as to provide at least 6' [1.8 m] of unobstructed deck to each side of the lift to accommodate easy maneuvering of the lift over the water and back.

#### **STEP 2:**

Locate the concrete anchor socket that came with your lift. Be careful to not lose the protective cap on the anchor. This will be used to keep dirt and debris out of the socket when the lift is not installed in the anchor.

#### **STEP 3:**

The setback to the center of the anchor will be 21" to 23", and can be determined from the chart on page 4. The anchor must be placed at the proper setback distance to ensure smooth operation of the lift.



#### **STEP 4:**

Ground the anchor according to your local requirements.

#### **STEP 5:**

Place the anchor in the proper location using the string level and string line to make sure the top of the anchor will be flush with the finished surface of the new deck. Place a small amount of concrete at the location of the anchor to hold it in place.

#### **STEP 6:**

Verify all your measurements for accuracy and pour the deck as you normally would, making sure not to get any concrete inside the anchor system. Allow the concrete to cure before installing and using the lift.

## LIFT INSTALLATION & ASSEMBLY- SUPER POWER-EZ

When the concrete or epoxy has fully cured the lift is ready for installation and assembly. To make assembly easier, the lift's mast section should be installed in the anchor first, as shown in this section.

Place the TURNING RING on the deck over the anchor with the relieved edge up. Carefully lower the post of the mast assembly into the anchor, until the MAST FLANGE rests on the top surface of the TURNING RING.

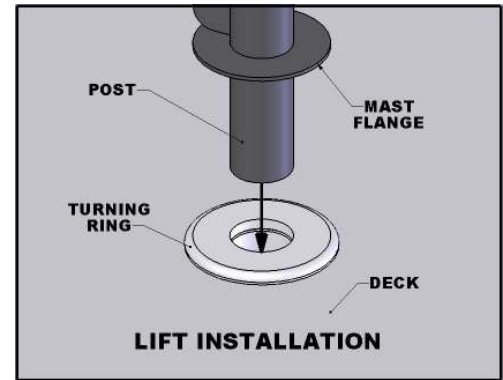

### **ASSEMBLY INSTRUCTIONS – SUPER POWER-EZ POOL LIFT™**

#### **REQUIRED TOOLS**

9/16" Wrench

3/4" Wrench

1/8" Hex Key (Power EZ)

Before beginning assembly layout all parts needed on a large, clean area.

#### **STEP 1:**

Connect the boom arm to the mast with one (1) 1/2" x 4" hex bolt, two (2) 1/2" flat washers and one (1) 1/2" nylock nut

#### **STEP 2:**

Connect the lower end of the electric actuator to the mast (vertical post) with one (1) 3/8" x 1-3/4" hex head bolt, two (2) 3/8" flat washers and one (1) 3/8" nylock nut.

#### **STEP 3:**

Connect the upper end of the electric actuator to the boom arm with one (1) 3/8" x 1-3/4" hex head bolt, two (2) 3/8" flat washers and one (1) 3/8" nylock nut.

#### **STEP 4:**

Locate the four (4) internal sling support bars and insert them into the sewn pockets in the mesh sling.

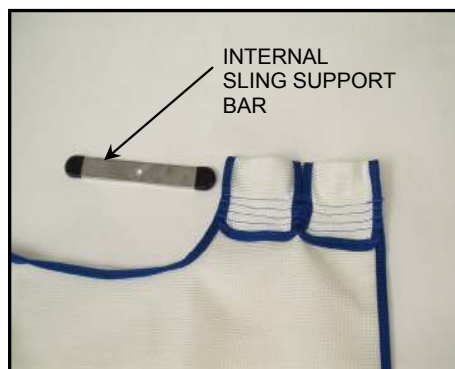

#### **STEP 1**

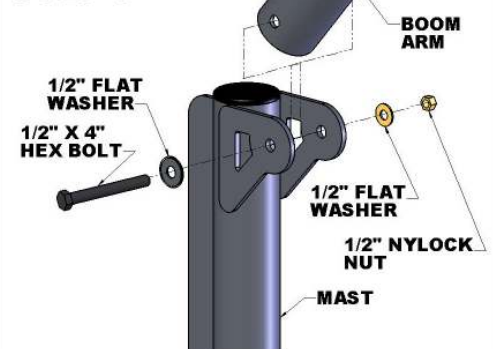

#### **STEP 2**

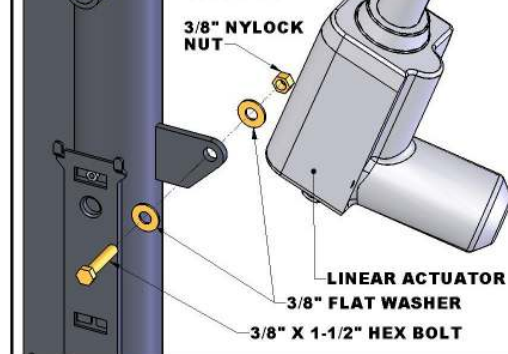

#### **STEP 3**

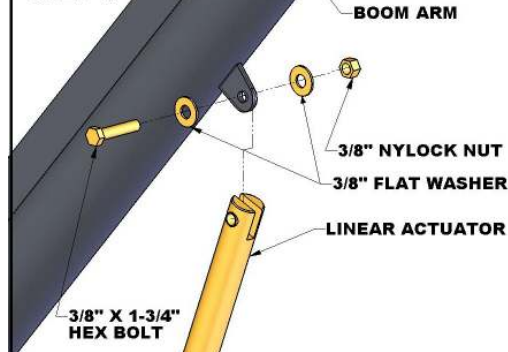

**STEP 5:**

Locate the chain assembly and insert each “S” hook into the holes in the sling support bars (A).

Attach the hanger to the boom eye on the lift (B).

Attach the chain links to the hanger so that the sling is at the appropriate height to allow the user easy access and so that the sling will clear your pool wall (C).

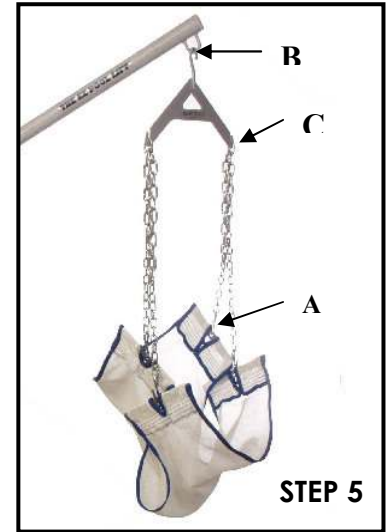

**STEP 6:**

Attach the control box by sliding it over the bottom of the mounting bracket until it reaches a positive stop and the holes in the control box and mounting bracket line up. Use the supplied #10-24 button head screw to secure the control box to the bracket.

**STEP 7:**

Attach the hand controller plug at the base of the control box. **Press firmly until plug is fully seated in the control box.**



STEP 7

**STEP 8:**

Mount the **\*FULLY CHARGED** 24V battery on top of the Control Box. When properly mounted the battery will lock into place and will sit flush and square with the control box. **ALWAYS RECHARGE THE BATTERY OVERNIGHT AND START EACH DAY WITH A FULLY CHARGED BATTERY.**

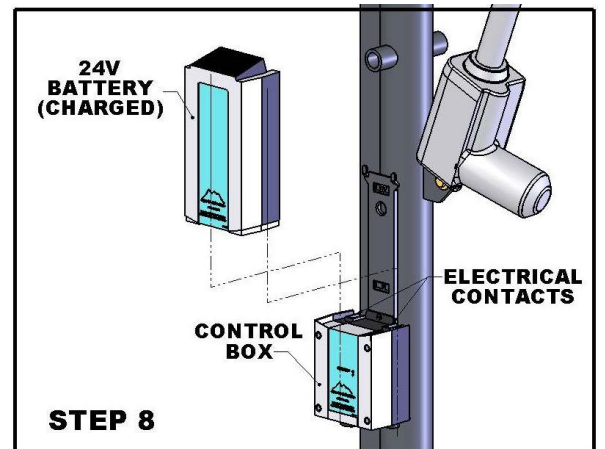
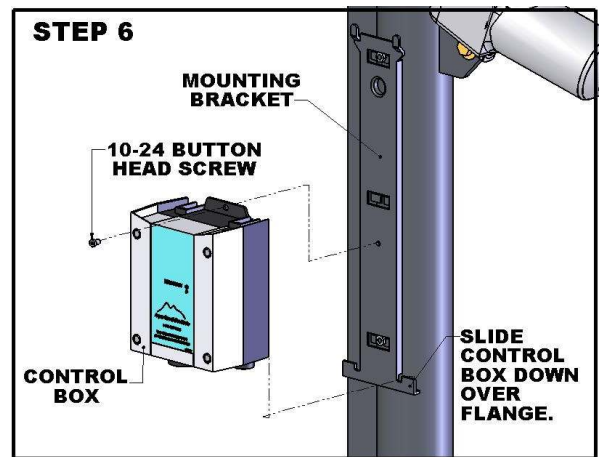

**\*ATTENTION: THE BATTERY ARRIVES UN-CHARGED AND MUST BE CHARGED FOR 24 HOURS BEFORE FIRST USE. STORE THE BATTERY ON THE CHARGER. NEVER LEAVE THE BATTERY ON THE LIFT WHEN NOT IN USE.**

## OPERATING INSTRUCTIONS – SUPER POWER-EZ POOL LIFT™

### NOTE:

- FOR SAFETY, CHECK FOR WORN PARTS AND LOOSE BOLT CONNECTIONS PRIOR TO EACH USE.
- ALL OPERATORS SHOULD BE FAMILIAR WITH ALL LIFT COMPONENTS AND THEIR INTENDED USES.
- OPERATORS SHOULD ALSO BE COMFORTABLE WITH ALL LIFTING

The SUPER Power-EZ Pool Lift™ requires the use of an operator to assist the lift occupant with the transfer into the pool. There are two methods of loading the lift occupant into the harness. The method of loading will depend on the physical ability of the lift occupant. If the user has very limited use of his/her upper body, it will be necessary to follow the procedure as follows. If the user is physically able, he can simply place himself into the harness without need for assistance. Once in the harness, it will be necessary for an operator to assist with the transfer into and out of the pool.

- With the lift in the up position and the boom arm located over the deck, roll the user under the lift and engage the brakes on the wheelchair.
- With the user facing the assistant, place the mesh seat sling under the seated user while still in the wheelchair.
- Attach the chain to the mesh sling and the overhead hanger bar. There should not be any slack in the chain at this time.
- Make sure all chain connections are secure and the mesh seat sling is level on each side.
- Raise the user by pressing the “up” arrow button on the controller until the desired height is achieved. The user should just clear the wheelchair.
- Rotate the lift using the turning bar so that the user is above the pool, keeping one hand on the boom and one hand on the user to stabilize them.
- Lower the user into the water by pressing the “down” button on the handheld controller until the user is submerged sufficiently in the water to allow an easy transfer to the pool.
- This procedure is repeated to remove a user from the water.
- When the lift is not in use, remove the sling, hanger bar and mast from the anchor socket and replace the protective anchor cap.

## **USING THE TURNING BAR**

**NOTE:** The turning bar is used to help turn the lift by placing the small end of the turning bar into one of the turning lugs on the mast and either pushing or pulling on the turning bar. Some will find it easier to pull, while others may prefer to push.

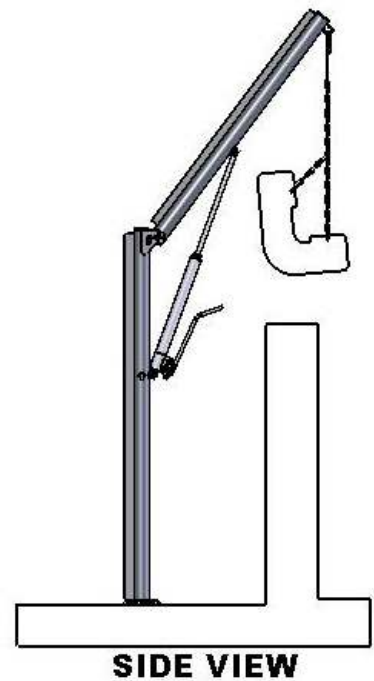
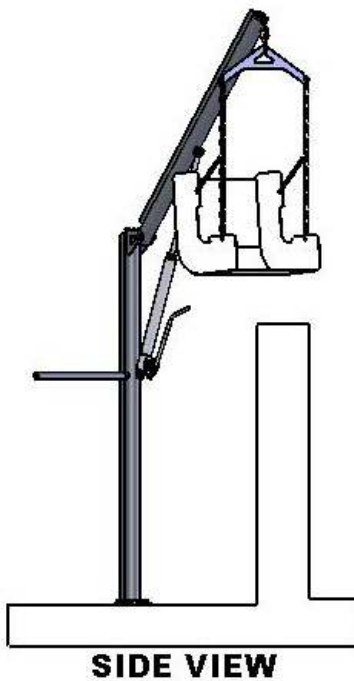
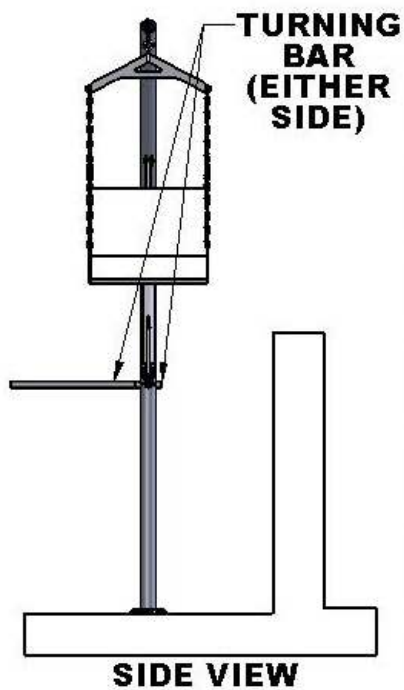
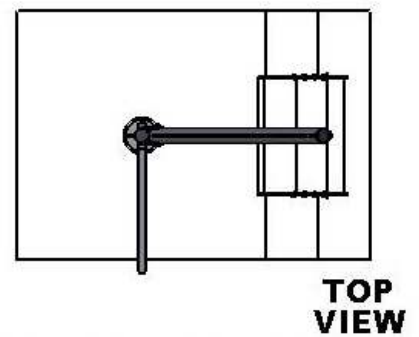
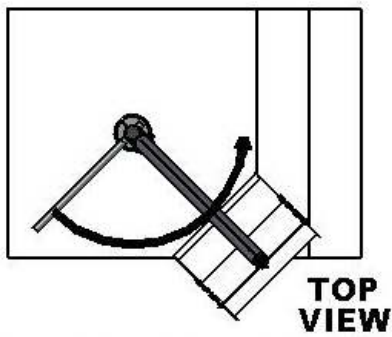
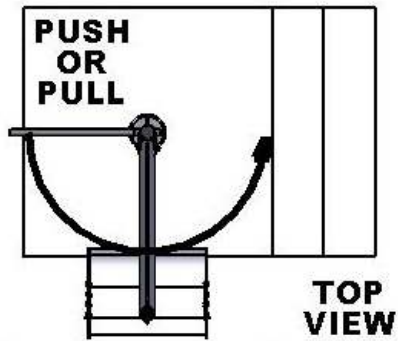

# 24V BATTERY SYSTEM OPERATING AND INSTALLATION INSTRUCTIONS



The SUPER Power-EZ Pool Lift™ battery system comes with a 24-volt sealed rechargeable battery, wall mount charging unit (with mounting bracket), control box, and a waterproof handheld controller. The control box is mounted to the SUPER Power-EZ Pool Lift™ and has a plug-in socket for both the actuator and the handheld controller. The battery mounts directly above the control box with a quick-release clip.

To operate the SUPER Power-EZ Pool Lift™ plug in the handheld controller to the control box and push the corresponding button to either lower or raise the unit. The lift should be able to complete approximately 10-20 full cycles before the low battery indicator audible tone will sound. The low battery indicator indicates approximately 20% battery life remaining.

At this point, **DO NOT ATTEMPT TO OPERATE THE LIFT**, remove the battery from the unit and recharge on the wall mount-charging unit.

To recharge the battery, simply grip the top of the battery and depress the clip on the back of the battery. This will unclip the battery from the control box bracket and the battery can then be clipped into the wall mount charger. When the charger is plugged in the green **ON** light will illuminate. When the battery is correctly mounted to the charger, the orange **CHARGE** light will illuminate. When the battery is fully charged, the **CHARGE** light will **GO OFF** and you can return the battery to the SUPER Power-EZ Pool Lift™.

## USING THE “EMERGENCY BUTTON”; SUPER Power-EZ Pool Lift™ Control Box

On the front of the control box is a small recessed button marked “emergency”. If you take a pen or pencil or other pointed object and depress the “emergency” button, this will bypass the remote control or handset and send a signal directly to the actuator to raise the seat out of the pool and back to the deck or up position.

**NOTE: this function will only work if there is sufficient power in the battery, the battery is properly attached to the control box, and the control box must be operating properly.**





**TIP:** *For optimal battery performance, please use these helpful tips.*

1. **RECHARGE THE BATTERY AS OFTEN AS POSSIBLE.**  
*The battery power unit is a sealed lead acid battery pack. Frequent recharges will prolong the battery life and maintain a high cold amperage capacity.*
2. *Do NOT expose the battery to freezing temperatures.*
3. *Do NOT expose the battery to prolonged periods of extreme heat or severe cold temperatures.*
4. *Protect your battery from long periods of direct sunlight. Heat will shorten your battery life. Optimum operating temperature is below 68 degrees Fahrenheit (20 degrees Celsius).*
5. *Never drop or bump the battery pack. This may result in loose or damaged internal connections, and may bend the battery terminals causing poor or lost contact with the control box.*
6. *Keep battery terminals clean and free from dirt and corrosion to ensure good contact.*
7. *Periodically use dielectric grease on the contact points to promote better conductivity.*

## TROUBLESHOOTING GUIDE (SUPER POWER-EZ)

Before troubleshooting make sure the battery is fully charged.

### **If the lift doesn't move when the handset button is pressed:**

When you can't get the lift to move check the following things:

1. Make sure the battery is fully charged:
  - A. Before charging the battery first make sure the **green** light on the front of the charger is illuminated (this means that the charger is on). Then check to make sure the silver contact points on the battery and charger are not damaged or corroded, and that they are clean. Then place the battery on the charger and look for the **orange** charge light to illuminate on the front of the charger. When the orange light goes off the battery is fully charged.

The top **green light** will always be illuminated indicating that it has power. When charging the battery the bottom **orange light** will illuminate, until fully charged.



- B. When the battery is correctly installed on the charger or control box you should hear a "click" indicating the battery is properly seated on the unit. Also note that when the battery is properly seated there should not be any gaps between the battery and the control box/charger.



**Not attached properly.** Note the white bracket is in front of silver clip, which will not allow for an electrical connection.



**Properly Attached.** Note that the white bracket is behind the silver clip. Not allowing movement.

**If the battery is fully charged and the lift is not moving then:**

2. Check all cords:

- A. Check that the cords are properly plugged in. Start by unplugging the remote and the actuator cord from the control box. Once these cords are removed check the ends for corrosion or damage. Plug the remote cord back in by lining up the raised tab on the plug to the grooved line on the control box outlet. Note that these cords require some force to plug them in fully. You will know they are correctly inserted when you hear a “popping sound”. The cords will be recessed into the outlet. If they are flush with the outside of the outlet they are not plugged in fully and the lift will not function. Make sure you do this for both cords.



**NOT inserted fully.**



**Fully inserted.**

**If you have checked all the cords and the lift still doesn't move:**

3. Check the contact points:

- A. After you have fully charged the battery and checked the cords to make sure they are properly plugged in, check to make sure the contact points are not corroded or bent. If the contact points are corroded take some rubbing alcohol and a q-tip and clean off the points. After cleaning the contact points it is recommended to put some dielectric grease on the contact points (terminals) to help ensure good electrical contact and prevent corrosion. Then reinstall the battery on top of the control box. Make sure you hear a “click”, which indicates that the battery is correctly seated. The lift will not work if the battery is not seated correctly.

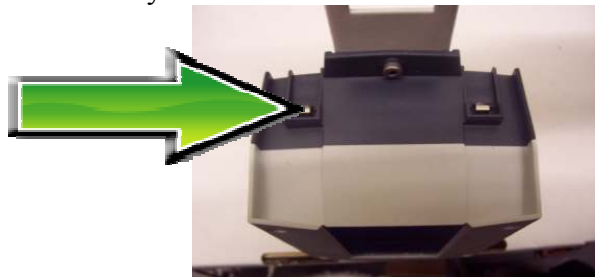

**Silver tabs are the contact (terminal) points.**

**If the lift stops moving over the water and is stuck:**

4. Then try pushing the emergency button:

A. If the lift gets stuck out over the water use a pen or pencil tip and stick it into the emergency button on the front of the control box to retract the lift. Note the lift will not retract if the battery is not fully charged or if the control box is not working. The emergency button only overrides the remote in case it has gone bad. If this does not retract the lift then chances are the remote is fine and you either have a problem with the battery, the control box, or the cords are damaged or not plugged in properly.

Use a pen or pencil tip to push in the small black circle located next to the word **emergency**, on the front of the control box.



## SAFETY AND MAINTENANCE INSTRUCTIONS

- Do not play on or around this lift
- Check the SUPER Power-EZ Pool LIFT™ before each use to assure there are no worn parts and that all hardware is properly tightened. If there are any worn parts, replace them BEFORE using the SUPER Power-EZ Pool Lift™. You can call our customer service at 1-888-687-3552 to order any parts.
- Aqua Creek Products, LLC lifts shall be grounded per local codes.
- At least ONCE A WEEK, the SUPER Power-EZ Pool Lift™ must be cleaned with fresh water.
- Do not spray the SUPER Power-EZ Pool Lift™ 24v battery unit directly with any pressure.
- Wipe all surfaces clean with a damp, non-abrasive cloth. When cleaning the SUPER Power-EZ Pool Lift™, use non-abrasive soap and water. Avoid harsh chemicals and disinfectants.
- Always read the label instructions on any cleaner carefully before applying it to a surface.
- The WARNING & INTENDED USE labels on the SUPER Power-EZ Pool Lift™ need to be maintained in readable fashion. If they become unreadable or faded, please replace the label immediately. Replacement labels are available from AQUA CREEK PRODUCTS LLC. 1-888-687-3552.

### CARE OF YOUR LIFT

Routine cleaning is an absolute necessity to ensure the integrity of the lift. Note that the Aqua Creek Pool Lift should not be stored in a pump room or in a storage room where pool chemicals are kept. Storing the lift near pool chemicals may cause rusting and other damage to occur. Your Aqua Creek stainless steel lift is powder coated to protect the stainless steel from rusting. Most rusting will occur at weld points, crevices, under gaskets, rivets or bolt heads.

The choice of a proper cleaning product is up to the consumer and there are many to choose from. Depending on the type of cleaning and the degree of contamination (rusting), some products are better than others. For routine cleaning the products most recommended are gentle soaps or detergents or dilute mixtures of ammonia. For stubborn spots and stains try using soft scrub with some brisk rubbing.

### DO NOT USE POOL WATER TO CLEAN USE ONLY FRESH WATER

If the lift is used **DAILY** make sure to wash the lift at the end of the day. Wash the lift off using a mild soap and a soft cloth. Make sure to pay special attention to weld points and crevices. Do not use a bristled brush or steel wool to clean the lift. Check that the lift is working properly and then place the battery on the charger. It is recommended that the battery be charged after every day of use.

If the lift is used **WEEKLY** follow the same steps as above. Also be sure to check all of the contact points (terminals) for damage or corrosion. If you notice corrosion gently clean the terminals. To clean corrosion from the terminals use a q-tip and some rubbing alcohol. If the corrosion is particularly stubborn try using a 3M scotch brite pad, but be careful not to damage the terminals. Apply dielectric grease to the terminals after cleaning them. This will help to prevent further corrosion. Do not leave the battery on the lift. Always store the battery on the charger whenever the lift is not being used.

If the lift is used **MONTHLY** follow the same steps as above. Also check the nuts and bolts to make sure they are securely fastened (this is always a good idea, no matter how often or infrequently the lift is used). Also make sure to store the battery on the charger and not on the lift. Leaving the battery on the lift for extended periods will significantly shorten the battery's lifespan.

If the lift is being **STORED** for an extended period of time follow all of the steps above. Check for rusting at all crevice and weld points. If you notice rusting spray some WD-40 on the affected area and take a 3M scotch brite pad and rub briskly. Afterwards be sure to wash and rinse the lift again with soap and water. When storing the lift make sure it is in a dry area and covered. **DO NOT STORE** in or around pool chemicals

## SUPER POWER-EZ PARTS LIST

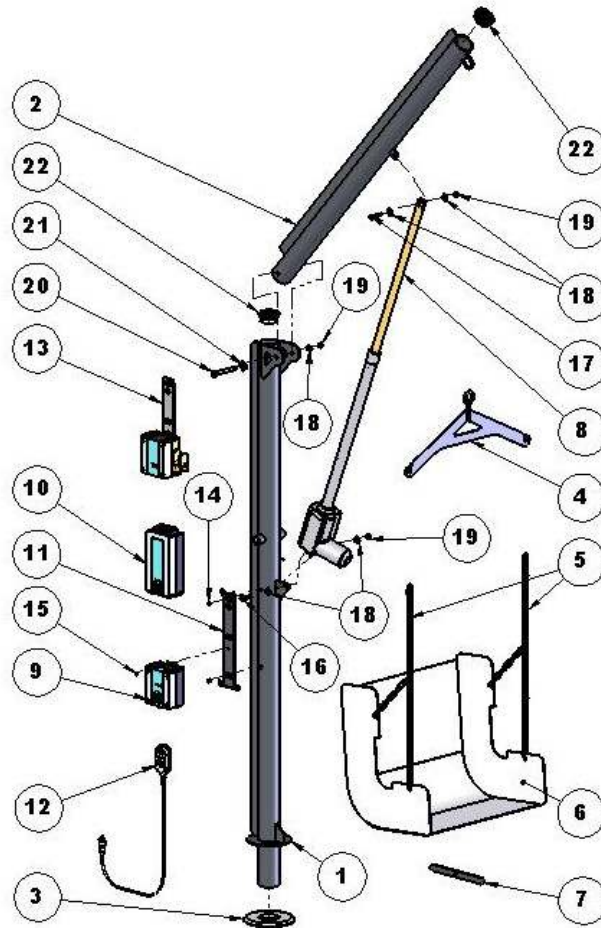

ITEM NO.	QTY	PART NUMBER	DESCRIPTION
1	1	SA-0808PEZTMA	SUPER POWER-EZ MAST ASSY.
2	1	SA-0808PEZTBA	SUPER POWER-EZ BOOM ASSY.
3	1	P-0808EZTMSP	SUPER EZ TURNING RING
4	1	F-034EZH	EZ POOL LIFT HANGER
5	1	F-031EZCH	EZ POOL LIFT CHAIN SET
6	1	F-034EZS	EZ POOL LIFT MESH SLING
7	4	F-032EZB	EZ POOL LIFT SLING BAR
8	1	F-499RAS	LA-34 ACTUATOR
9	1	F-40CBJ	CONTROL BOX
10	1	F-004AB	24VDC LEAD-ACID BATTERY
11	1	MBJ2-01	CB/BATTERY MOUNTING BRKT
12	1	F-100JH	HANDSET CONTROL
13	1	F-044CH	BATTERY CHARGER
14	2	NUT1024SSHEX	10-24 HEX NUT, SS
15	1	SCREW10-24BHSS	10-24 BUTTON HEAD CAP SCREW
16	1	BOLT3/8-16X11/2SS	3/8" X 1-1/2" HEX BOLT, SS
17	1	BOLT3/8-16X13/4SS	3/8" X 1-3/4" HEX BOLT, SS
18	5	FLATWASHER3/8SS	3/8" FLAT WASHER, SS
19	3	NYLOCKNUT3/816SS	3/8"-16 NYLOCK NUT, SS
20	1	BOLT1/2X31/2SHLDRSS	1/2" X 3-1/2" SHOULDER BOLT, SS
21	1	FLATWAHSER1/2SS	1/2" FLAT WASHER, SS
22	2	CAP	PLASTIC CAP

# **Aqua Creek Products, LLC Limited Warranty:** **SUPER POWER-EZ™ POOL LIFT**

Aqua Creek Products lifts have a **Limited Lifetime Warranty** on the frames, not including the powder coat finish. Aqua Creek Products, LLC (a.k.a. Aqua Creek) also warrants to the original end user that all non-frame components manufactured by Aqua Creek, when properly installed in accordance with assembly and installation instructions, and properly used and maintained, shall be free from defects in material and workmanship for a period of five (5) years from the date of original purchase, provided that Aqua Creek receives prompt notice in writing of any defect or failure and satisfactory proof thereof, with the following exceptions:

**Exception 1:**

The mesh sling shall have a warranty period of one (1) year from the date of the original purchase.

**Exception 2:**

All electrical components, including the linear actuator shall have the following warranty period:

Year 1-2: 100% Coverage

Year 3: 60% Coverage (Customer is responsible for 40% of replacement cost)

Year 4: 50% Coverage (Customer is responsible for 50% of replacement cost)

Year 5: 40% Coverage (Customer is responsible for 60% of replacement cost)

This warranty specifically excludes reimbursement for labor to remove, repair, or install the product and any return freight charges.

These warranties do not cover any damages due to accident, misuse, abuse, negligence or failure to properly maintain any products, or normal wear and tear from day to day operations. In the event that any products are altered, repaired, or improperly installed or improperly used by anyone without the prior written approval by Aqua Creek, all warranties are void. **IMPORTANT: AMOUNT OF WEIGHT PLACED ON LIFT SHALL NOT EXCEED THE RATED LIFTING CAPACITY OF 400 POUNDS [181 kg] FOR THE SUPER POWER-EZ LIFT.**

To initiate a warranty claim, the owner of an Aqua Creek product must provide the place of purchase, in writing, with a full description of the product, its serial number, the dates of purchase and installation, and the exact nature of the defect. Within thirty (30) days after receipt of a written warranty claim by Aqua Creek, and barring any unforeseen delays, the place of purchase will be notified of Aqua Creek's decision regarding the claim.

If requested by Aqua Creek, any defective product must be returned, freight prepaid, to Aqua Creek's designated factory location or duly appointed distributor for inspection and/or repair. Aqua Creek will, at its option, repair or replace the failed or defective item, and deliver the repaired product or replacement to the buyer of the product, freight prepaid to the destination provided for in the original order. Products returned to Aqua Creek for which Aqua Creek provides replacement under this limited warranty shall become the property of Aqua Creek.

A new warranty period shall NOT be established for the repaired or replaced products. Such products shall remain under warranty only for the remainder of the original warranty period on the original products purchased.

This written limited warranty constitutes the final, complete and exclusive statement of warranty terms. No person or organization is authorized to make any other specific or implied warranties or representations on behalf of Aqua Creek.

THE WARRANTIES SET FORTH HEREIN ARE IN LIEU OF ALL OTHER WARRANTIES, EXPRESSED OR IMPLIED, WHICH ARE HEREBY DISCLAIMED AND EXCLUDED, INCLUDING WITHOUT LIMITATION ANY WARRANTY OF MERCHANTABILITY OR FITNESS FOR A PARTICULAR PURPOSE OR USE.

THE SOLE AND EXCLUSIVE REMEDIES FOR BREACH OF ANY AND ALL WARRANTIES WITH RESPECT TO THE PRODUCTS SHALL BE LIMITED TO REPAIR OR REPLACEMENT AT AQUA CREEK'S DESIGNATED FACTORY LOCATION, OR DULY APPOINTED DISTRIBUTOR, OR IN PLACE AT AQUA CREEK'S OPTION. IN NO EVENT SHALL AQUA CREEK'S LIABILITY EXCEED THE ENTIRE AMOUNT PAID TO AQUA CREEK BY THE ORIGINAL PURCHASER FOR THE FAILED OR DEFECTIVE PRODUCT.

IN NO EVENT SHALL AQUA CREEK PRODUCTS, LLC BE LIABLE FOR ANY INCIDENTAL, CONSEQUENTIAL, SPECIAL, INDIRECT, PUNITIVE OR EXEMPLARY DAMAGES OR LOST PROFITS FROM ANY BREACH OF THIS LIMITED WARRANTY OR OTHERWISE.

Aqua Creek Products  
9889 Garrymore Lane  
Missoula, MT 59808

