

THE PRO SPA LIFT™- 24V BATTERY

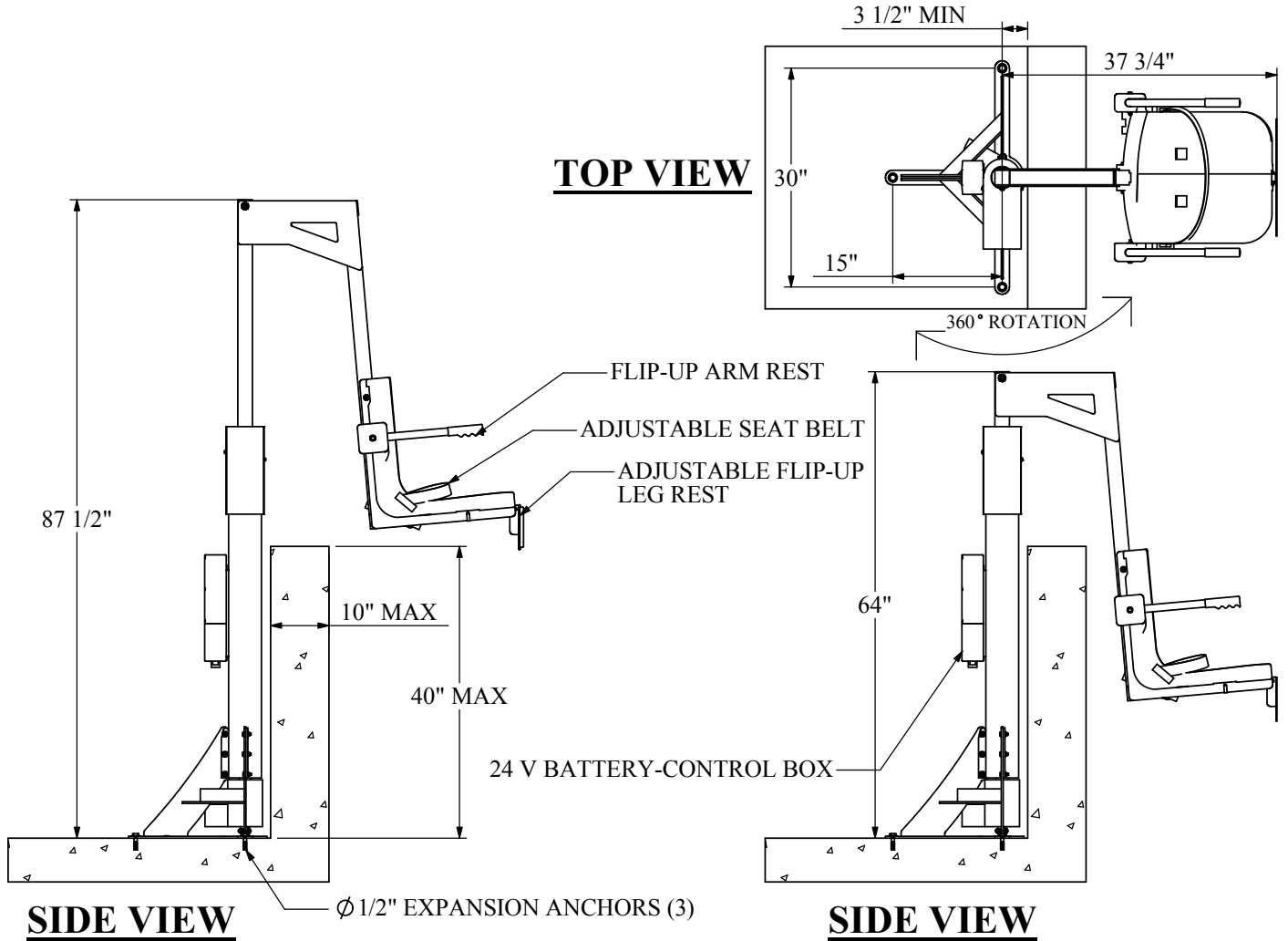

SPECIFICATIONS

THE AQUA CREEK PRO SPA LIFT -BATTERY SHALL BE A SELF-OPERABLE 24 VOLT, ELECTRONICALLY ACTUATED ABOVE GROUND HOT TUB OR SPA LIFT. THE LIFT SHALL BE POWERED BY A 24V RECHARGABLE BATTERY CAPABLE OF BEING REMOVED FOR CHARGING. THE LIFT SHALL BE STAINLESS STEEL CONSTRUCTION WITH A LIFTING CAPACITY OF 300 LBS. THE LIFT SHALL BE CAPABLE OF CLEARING A 40" HIGH, 10" WIDE WALL. THE HOUSING SHALL BE MOUNTED TO THE DECK USING THREE ANCHOR POINTS. THE LIFT SHALL BE POWERED UP AND DOWN, AND SHALL ROTATE 360° IN EITHER DIRECTION. THE PRO SPA ELECTRIC SHALL INCLUDE AN ADJUSTABLE SEAT BELT, ADJUSTABLE PULL-OUT LEG REST, AND A FLIP-UP ARM REST. A 5-YEAR LIMITED WARRANTY IS STANDARD. ALL MOUNTING HARDWARE SHALL BE INCLUDED.

- BATTERY: 24 V DC RECHARGABLE BATTERY PACK
- MAIN HOUSING: Ø4" SCHEDULE 10 PIPE STAINLESS STEEL TYPE 304
- CHAIR ARM: 2" SQUARE TUBE STAINLESS STEEL TYPE 304
- CHAIR: ROTATIONALLY MOLDED UV STABILIZED POLY-ETHEYLENE (LLDPE)
- ANCHORS: 1/2" DROP-IN EXPANSION ANCHORS (3) STAINLESS STEEL TYPE 304
- FINISH: UV RESISTANT POLYESTER POWDER COATING

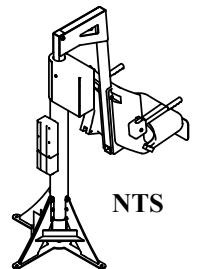

3015 W. RAILROAD ST. #8
 MISSOULA, MT 59808
 (406) 549-0769
 FAX (406) 549-2602

NOTE:
 *SPECIFICATIONS ARE SUBJECT TO CHANGE WITHOUT NOTICE
 *ALL DIMENSIONS ARE IN INCHES

PRODUCT:		F-006PSLB	
DWG #:		F-006PSLB	
SCALE:	1:24	DATE:	09/10/06
DRAWN BY:	DS	REVISION:	B